

electro-harmonix

effects interface

HARDWARE PLUGIN[®]

Welcome to the Electro-Harmonix Effects Interface Hardware Plugin[®], the bridge between computer audio and your pedalboard. Use the Effects Interface to insert any of your guitar pedals as a plugin on your DAW, or use it to add any plugin from your DAW as an effect on your pedalboard. The Effects Interface can also be used as a 2-in-2-out USB Audio interface for your computer, optimized for guitar and other instrument-level or line-level signals.

Features Include:

- ▶ The Effects Interface acts like a standard DAW plugin but your tracks are processed through any real pedal(s) you choose.
- ▶ Hosts any plugin from your computer to use live on your pedalboard.
- ▶ Works alongside your main audio interface.
- ▶ Integrates with DAWs such as Pro Tools[®], Ableton Live[®], Cubase[®], Logic Pro[®], Reaper[®], and more.
- ▶ Functions as a 2 In/2 Out USB Audio recording interface.
- ▶ Power through USB, supplied AC Adapter, or most third-party pedal power supplies.

Table of Contents

Quick Start Guide	2
Hardware Overview	5
Software Overview	6
Operating Instructions	9
Updating the Effects Interface	12
MIDI Configuration	13
Tips and DAW Notes	14
Technical Specifications	15

IN THE BOX:

Effects Interface
Hardware Plugin[®]
9.6VDC / 200mA Power Supply
USB-C Cable
User Reference Manual
Warranty/Compliance Insert

POWER SUPPLY REQUIREMENTS:

Voltage: **9VDC** Current: **125mA**
Polarity: **Center-Negative**

This device comes equipped with an Electro-Harmonix 9.6DC-200 power supply. Use of the wrong adapter or a plug with the wrong polarity may damage the device and void the warranty. Do not exceed 12VDC on the power plug. Power supplies rated for less than 150mA may cause the device to act unreliably.

Quick Start Guide

Install the software available from the Effects Interface product page at www.ehx.com/effectsinterface. Connect the device to your computer.

Hardware Plugin® Mode

To use a physical guitar pedal as a plugin in your DAW, open your DAW of choice and select “Effects Interface” from your list of installed plugins. Open the Effects Interface plugin’s menu, hover over Select Device, and choose “Audio” mode.

Note: Check your DAW settings to ensure it is not using the Effects Interface for MIDI or audio input/output/sync.

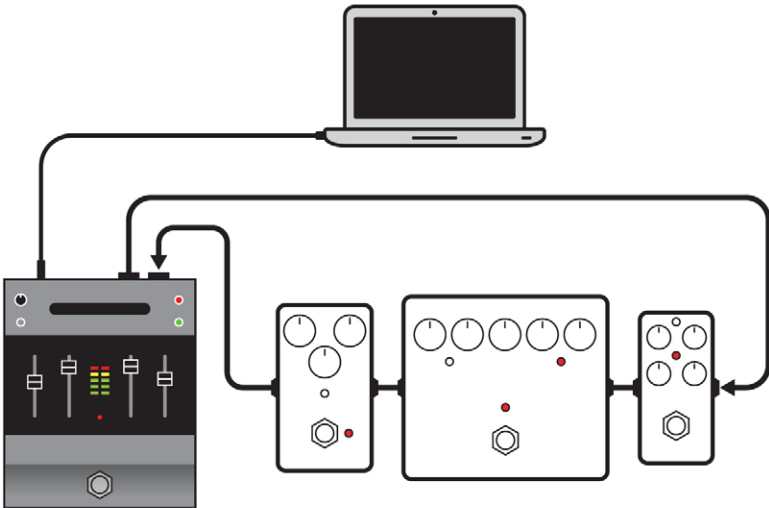

Hardware Plugin® Signal Flow

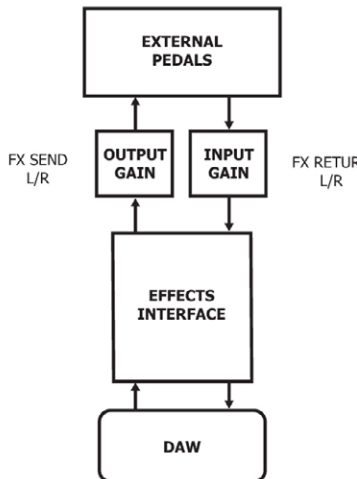

Pedalboard Mode

To use one of your plugins as a guitar pedal on your pedalboard, add the “Effects Interface” to a track in your DAW. In the Select Device menu, choose “Pedalboard>IN”. Add your desired plugin(s) to the track, then add another FX Loop plugin and select “Pedalboard>OUT.”

Note: Check your DAW settings to ensure it is not using the Effects Interface for MIDI or audio input/output/sync.

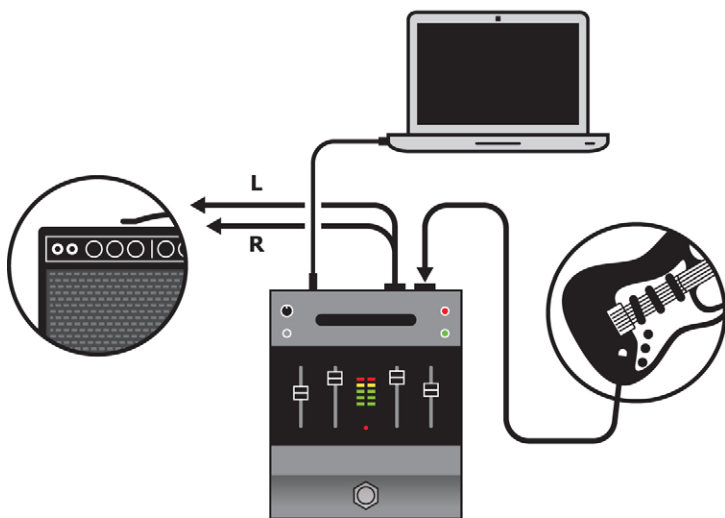

Pedalboard Mode Signal Flow

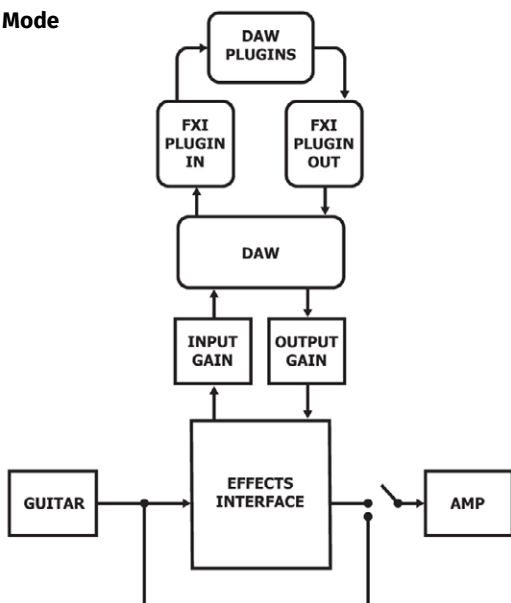

Audio Interface Mode

To use the Effects Interface as an Audio Interface, open the preferences for your DAW, and select Electro Harmonix FX Loop as your audio input/output device.

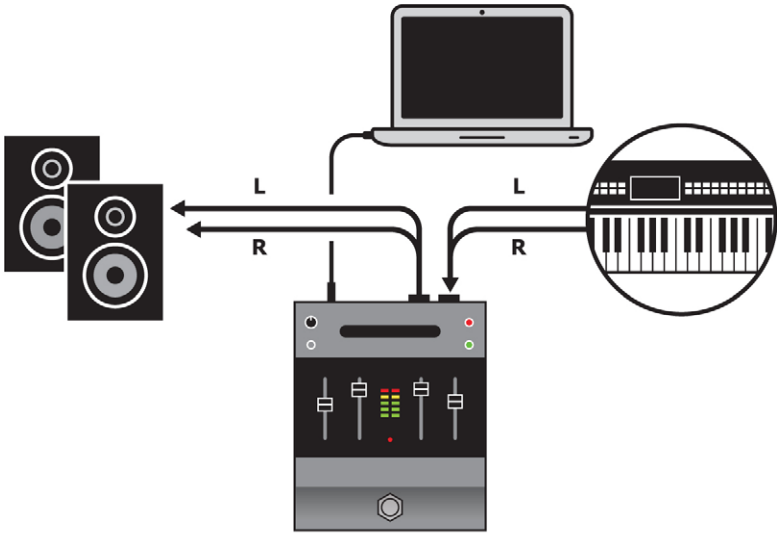

Audio Interface Signal Flow

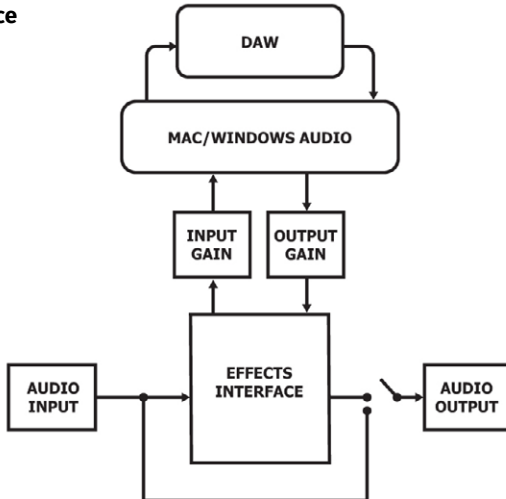

Hardware Overview

Front Panel Controls



- 1. POWER LED** Lights when the unit is powered up.
- 2. USB LED** Lights red when USB is connected. Lights green when a successful connection has been made to the plugin in Audio or Pedalboard modes.
- 3. INPUT Sliders L/R** Sets the level of the signal into the Effects Interface from the INPUT L and R jacks.
- 4. INPUT Meter LEDs** Light up when signal is present at the INPUT L and R jacks. When more LEDs are lit, the signal level is higher. The orange LED lights when the signal level is above -6dB, and the red LED lights when the signal is above -3dB.
- 5. FOOTSWITCH and STATUS LED** When using the Effects Interface on your pedalboard, press this footswitch to switch between bypass and effect modes.
- 6. OUTPUT Sliders L/R** Sets the level of the signal sent by the Effects Interface on the OUTPUT L and R jacks.
- 7. DIRECT MONITOR Button** When using the Effects Interface as your audio interface or standalone, press this button to monitor (hear) the signal from the INPUT jacks.
- 8. Headphone LEVEL Knob** Sets the volume level of headphones inserted into the Headphone jack.

Top Panel Controls

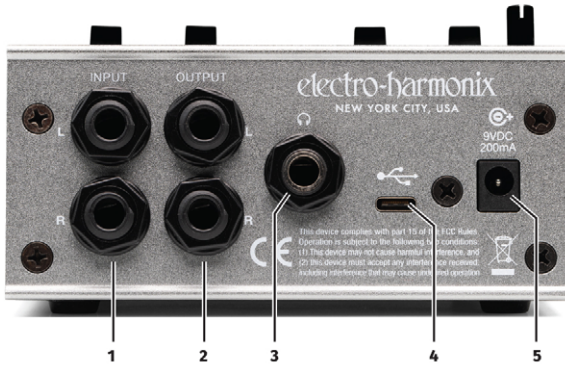

- 1. INPUT Jacks L/R** Audio input for the Effects Interface. To use a physical guitar pedal as a plugin in your DAW, plug that pedal's output into one of these jacks.
- 2. OUTPUT Jacks L/R** Audio output from the Effects Interface. To use a physical guitar pedal as a plugin in your DAW, plug this into that pedal's input jack.
- 3. Headphone Jack** Stereo headphone output of the Effects Interface. The headphones output the signal present at the L/R OUTPUT Jacks.
- 4. USB-C Port** Connect this to a USB port on your computer to use the Effects Interface with your DAW. The Effects Interface can be entirely powered by USB.
- 5. 9VDC 200mA Power Jack** Plug the EHX 9VDC-200mA adapter, center negative, into this jack when using the Effects Interface as a standalone pedal.

Software Overview

1. Settings Menu Button

Select Device Lists available Effects Interface devices. The device option will be greyed out if another plugin instance is currently using said device. You have the option of choosing *Audio*, *Control*, or *Pedalboard* mode when selecting a device.

Audio Mode: Select this to use the Hardware Plugin® functionality of the Effects Interface, routing audio from the DAW to the pedals connected to the hardware unit.

Control Mode: Select this to use your DAW to control the parameters of the Effects Interface without routing audio to it. This can be used as remote-control while the pedal is used standalone.

Pedalboard Mode: This mode lets you use your DAW plugins on your pedalboard. The instrument at the input jacks is routed through your DAW plugins. Note: You must use both an "IN" and an "OUT" plugin instance for the audio to be routed to and from the DAW.

Disconnect: Ends the connection between the plugin and Effects Interface. Use this option when you want to disconnect from one plugin instance and connect on a separate instance. Disconnection is done automatically when the plugin is deleted or the DAW is closed.

About Hardware Displays hardware information (device name, serial #, version #). When a device is selected, the Device Options item becomes available, where the Effects Interface's USB Audio settings can be adjusted.

Device Options: Controls the Effects Interface's USB Audio settings. Adjust these settings to provide the best combination of stability and low latency. Slower or older computers may need larger buffer and block sizes to maintain stability.

Speed Control: Synchronizes audio streaming between the DAW and the Effects Interface. This should typically be kept on for stable audio but can create occasional "phasing" sounds on some systems. Turn off when absolute short-term agreement is necessary between wet and dry signals.

About Plugin Displays the software version number and the Update Plugin option, which can be used to update the software plugin.



Plugin Settings Menu, and the Select Device submenu.



Plugin interface, Stereo mode.

2. POWER LED Lights red when the Effects Interface plugin is connected to the hardware.

3. USB LED Lights when the software plugin is connected to the Effects Interface hardware. It lights green in Audio and Pedalboard modes, and lights red in Control mode.

4. INPUT Level Section Controls how much signal from the INPUT jacks is sent to the DAW track. In Audio mode, this sets the level of the return signal from the external pedal(s). In Pedalboard mode, this sets the input level from the guitar. The LED button functions as a stereo link for the sliders; if illuminated, moving one slider controls both sliders. If not illuminated, each slider controls its own channel of gain.

If a mono (L or R) plugin instance is selected, only one slider will be visible and there will be no link button.

5. INPUT Meter LEDs Light up when signal is present at the INPUT L and R and the plugin is connected to the hardware. The orange LED lights when the signal level is above -6dB, and the red LED lights when the signal is above -3dB. Above this meter, recent peak levels are displayed.

6. BYPASS Footswitch & STATUS LED Press the BYPASS switch to enable or disable the Effects Interface loop. When the associated LED is lit, the effect is active. When the LED is off, the unit is in bypass mode.

7. OUTPUT Level Section Controls how much signal is sent from the DAW to the OUTPUT jacks. In Audio mode, this sets the signal level going into an external pedal. In Pedalboard mode, it sets the signal level going into your amplifier. The LED button functions as a stereo link for the sliders; if illuminated, moving one slider controls both sliders. If not illuminated, each slider controls its own channel of gain.

If a mono (L or R) plugin instance is selected, only one slider will be visible and there will be no link button.

8. MIX Knob In Audio Mode, this knob controls the mix between a dry signal (the signal going into the plugin) and the signal on the INPUT jack(s) of the Effects Interface.

Operating Instructions

Installing Software and Connecting to a Computer

Before connecting the Effects Interface to your computer, you must install the VST/AU/AAX software plugin and drivers for the Effects Interface. Go to www.ehx.com/effectsinterface to download the appropriate installer for your computer's OS (Mac, Windows). The Windows installers will install Thesycon USB Audio drivers for Electro-Harmonix Hardware Plugins. Approve installation if prompted to trust the software.

Connect the Effects Interface to your computer using the supplied USB-C cable. Upon making the connection, the computer may install drivers for the device, after which the Effects Interface is ready to use.

Using the Effects Interface as a Hardware Plugin®

1. Connect the pedal(s) you want to insert into your DAW to the Effects Interface's INPUT and OUTPUT jacks.
2. Open up your DAW. You may need to open your DAW's audio and MIDI settings. Set your DAW's audio input/output to your usual audio interface, **not** the Effects Interface. Disable all MIDI input/output/sync for the Effects Interface.
3. Select a track or channel and open the menu for plugins. Find and select Electro-Harmonix -> Effects Interface.

4. **VERY IMPORTANT:** You must connect the software plugin to the Effects Interface unit for the audio to reach the hardware:
 - a. Open the plugin's graphic interface and click the Settings menu in the upper right corner of the toolbar. 
 - b. Hover over Select Device. Select Device will be greyed out if the Effects Interface is not properly connected to the computer.
 - c. Under the heading FXI-[4 digit serial number], you will see options for Audio, Control, and Pedalboard. Hover over *Audio*, then select Stereo or Mono. The USB light on both the software plugin and Effects Interface will turn green.
 - d. If this is the first time you have used this Effects Interface unit with this computer, a hardware calibration screen will appear. Click "Calibrate" to adjust the Effects Interface's settings to your computer, then click "Done."
5. Press play on your DAW. The audio of the selected track will now pass through the pedal(s) you have connected to the Effects Interface. Press the bypass foot-switch on the Effects Interface hardware or plugin to bypass the external pedal.

Integrating the Effects Interface Into Your Pedalboard

There are two ways to use the Effects Interface as a pedal on your pedalboard:

Pedalboard Mode: Routes audio onto a single track on your DAW. This allows you to use other channels on your DAW independently of the Effects Interface, and lets you use another audio interface at the same time.

Audio Interface Mode: Uses the Effects Interface unit as your DAW's main input/output device, so an Effects Interface plugin is not needed. This has the lowest latency but won't allow use of your DAW for anything else.

Using The Effects Interface in Pedalboard Mode

1. Connect your guitar or other instrument to the INPUT jack(s) of the Effects Interface, and connect the OUTPUT jack(s) to your amp(s).
2. Open up your DAW. You may need to open your DAW's audio and MIDI settings. Set your DAW's audio input/output to your usual audio interface, **not** the Effects Interface. Disable all MIDI input/output/sync for the Effects Interface.
3. Select a track or channel and open the menu for plugins. Find and select Electro-Harmonix -> Effects Interface.
4. **VERY IMPORTANT:** You must connect the software plugin to the Effects Interface unit for the audio to reach the hardware:
 - a. Open the plugin's graphic interface and click the Settings menu in the upper right corner of the toolbar. 
 - b. Hover over *Select Device*. *Select Device* will be greyed out if the Effects Interface is not properly connected to the computer.
 - c. Under the heading FXI-[4 digit serial number], you will see options for Audio, Control, and Pedalboard. Hover over Pedalboard > IN, then select

Stereo or Mono. The USB light on both the software plugin and Effects Interface will turn green.

- d. If this is the first time you have used this Effects Interface unit with this computer, a hardware calibration screen will appear. Click “Calibrate” to adjust the Effects Interface’s settings to your computer, then click “Done.”
5. Add the plugin(s) you want on your pedalboard to the track, after the Effects Interface plugin.
6. Add another instance of the Effects Interface plugin, after all the other plugins. This plugin instance must also be connected to the hardware:
 - a. Click the Settings menu on the upper right corner of the toolbar.
 - b. Hover over Select Device > FXI-[4 digit serial number] > Pedalboard > OUT and select Stereo or Mono.
7. Your guitar signal will now be routed through the plugins on your DAW, then out to your amp. Press the bypass footswitch on the Effects Interface hardware or plugin to bypass the DAW plugins.

Tip: *To reduce latency in this mode, open the **Device Options** menu in **Settings > About Hardware**, and reduce the buffer and block sizes to the smallest setting that doesn’t cause audio skips. Some plugins will also have their own latency that adds to the total delay you will experience.*

Using the Effects Interface as an Audio Interface

1. Open the preferences for your DAW, and select Electro Harmonix USB Audio or FXI-[4 digit serial number] as your audio input/output device.
2. Plug your input(s) into INPUT L/R. The OUTPUT L/R jacks can connect to monitors or speakers, or you can monitor using the headphone jack.
3. Do not use the Effects Interface software plugin while using the Effects Interface hardware as an audio interface.
4. You can use the Effects Interface on your pedalboard in this mode by adding plugins to a track and monitoring the track output. The bypass footswitch will bypass the processing on the DAW.

Using Two Plugins Simultaneously – Dual Mono

Two separate Effects Interface instances can be used on separate tracks by adding Mono L and R plugins to each track. Follow the Select Device process for each instance. When one mono side is connected, it will be greyed-out in other instances of the plugin. This is available for any mode (Audio, Control, or Pedalboard) but both plugins must connect in the same mode.

Updating the Effects Interface

Updating the Software Plugin

Upon opening the plugin while connected to the Internet, the plugin will prompt a message indicating there is a new version of the software plugin to install. If you wish to install the newest version, press OK and it will open the installer download page on www.ehx.com/effectsinterface. Download and run the installer to get the most current version of the software plugin.

Updating the Pedal Firmware

Upon opening the plugin while connected to the Internet, the plugin will show the message “Firmware Update Required...” indicating there is a new version of the firmware to install on the Effects Interface hardware. If you wish to install the newest version, click on the message and the plugin will navigate you through its firmware update process.

1. The plugin will ask if you want to update the Effects Interface’s firmware. Press ‘OK’ to proceed with the update.
2. Various LEDs on the Effects Interface unit will blink. **Do not disconnect the unit, delete the plugin, or quit your DAW or else the firmware upgrade process will fail.**
3. Once the download has completed, the Effects Interface will restart and you can reconnect it to the plugin.

Resetting Firmware

If for some reason the Effects Interface does not start up or function normally, you may reset it to its factory firmware. There are two ways to do this:

Method 1

1. Connect the Effects Interface to your computer and assign it a software plugin instance.
2. Hold the Option key (Mac) or Alt key (PC) while clicking on the Settings menu.
3. Hover over *About Hardware*, click on *Reset Firmware*, then press OK.
4. The left meter LEDs will cascade downward, then the pedal will restart. The firmware is now reset to the factory setting.

Method 2

1. Remove the bottom cover of the Effects Interface by unscrewing two chassis screws on the front and four screws on the back of the unit.
2. Find the “Reset to Factory Firmware” button, on the top-right of the PCB, near the 9VDC Power Jack. Hold this button while power cycling (removing the USB or AC adapter from the unit and plugging it back in).
3. The left meter LEDs will cascade downward, then the pedal will restart. The firmware is now reset to the factory setting.

MIDI Configuration

In addition to the plugin's Audio, Control, and Pedalboard modes, the Effects Interface can be controlled via MIDI, without using the DAW plugin. Send the appropriate MIDI message from your computer using MIDI over USB, and the Effects Interface will adjust its parameters accordingly.

Note: MIDI control is disabled when the Effects Interface is connected to the plugin.

MIDI Configuration Mode

1. Unplug the Effects Interface and hold the Direct Monitor button while plugging it in, then release the button. The Direct Monitor button will blink.
2. To enable/disable MIDI Send/Receive, press the Direct Monitor button to cycle through the options. MIDI Send is active when the LEFT meter LEDs are lit. MIDI Receive is active when the RIGHT meter LEDs are lit.
3. Press the footswitch to advance to MIDI channel selection. The selected MIDI channel will be shown by the number of meter LEDs lit (one light for Channel 1, two lights for Channel 2, etc.). Press the Direct Monitor button to cycle through MIDI Channels.
4. Press the footswitch to save the MIDI settings and return to normal operation.

MIDI Control Change Chart

Function	CC#	Value
Input Gain (both)	105	0-127
Input Gain L	106	0-127
Input Gain R	107	0-127
Bypass Footswitch	110	64: engage 0: bypass
Output Level (both)	112	0-127
Output L	113	0-127
Output R	114	0-127
Omni Off	124	Any
Omni On	125	Any

MIDI Program Change Chart

Function	PC#
Toggle Bypass on/off	11

Tips and DAW Notes

Tips for Successful Operation

Sample Rates & Audio Settings: If you don't hear anything from the Effects Interface, you may need to check the audio settings for your DAW and computer:

- Your DAW's sample rate must be set to 44.1, 48, 88.1, or 96 kHz. Other sample rates are not supported.
- Check the audio settings on your DAW and computer to make sure your Effects Interface is not being used as an audio input/output device while trying to use the plugin.

Disable Offline Rendering/Bouncing: Any rendering, bouncing, or freezing of tracks with the Effects Interface must be done in real-time, since the signal is converted to analog and sent through outboard pedals in real-time.

Disable MIDI connection to the Effects Interface: In some DAWs, the Effects Interface will be detected as a MIDI input/output and the DAW will automatically connect to it with MIDI. This prevents the hardware from connecting to the plugin. Check the MIDI settings of your DAW and disable MIDI input/output/sync for the Effects Interface in order to connect.

Pedalboard Mode Tips

Getting Streaming Audio: In some DAWs, you must populate the track with an audio or MIDI region in order to process audio on that track and pass audio through the plugins. Additionally, some DAWs require that you press play and see a moving playhead in order to send audio to plugins. Getting pedalboard mode to work may require some experimentation with your system.

Latency: Pedalboard mode sounds best at the lowest possible latency that still allows for smooth audio streaming. Lowering the latency means using the lowest possible buffer (sometimes called "block") sizes in both the Effects Interface hardware and the DAW.

Reaper® – Disable Anticipative Processing

Reaper's Anticipative Processing must be disabled for the Effects Interface to stay in sync with other audio. This is found in Reaper's preferences menu, under Audio > Buffering.

Logic Pro® – Audio Mode and Logic's Low Latency Mode

In Logic Pro, enabling Low Latency Mode will bypass the Effects Interface. The Effects Interface will be re-activated when recording is completed, returning the effect to the track. To avoid this, disable Low Latency Mode.

Pedalboard Mode Latency: Users can change the main I/O buffer sizes in Logic, but Logic will still often pass buffer of 1024 samples to plugins. To circumvent this, you can set up a MIDI or Software Instrument track, populate this track with a blank MIDI region, and then set up the Effects Interface in the Pedalboard Mode configuration. On a MIDI track the buffers passed to the plugin match Logic's settings.

Pro Tools® (Windows-Only) – MIDI Port management

When using with Pro Tools on Windows, an “ExcludedMIDIPorts.txt” file must be created to prevent Pro Tools from taking control of the Effects Interface as a MIDI port. The first time you connect the hardware to the plugin in Pro Tools, you should be prompted to create this file. If you do not see the prompt, make sure your device is connected to the plugin, then open the Settings menu. Click on “Setup Pro-Tools...” which will replace other menu options until the process is complete.

A dialog box will open to guide you through the process of creating the file and copying it into your Pro Tools directory. Once this is complete, restart Pro Tools to use the Effects Interface.

Technical Specifications

- ▶ Audio input impedance at each INPUT jack: 2Mohms
- ▶ Audio output impedance at each OUTPUT jack: 330ohms
- ▶ Current draw: 125mA
- ▶ Power Supply: USB/5V or 9VDC-200mA, center negative
- ▶ Sample rate: 44.1, 48, 88.1, or 96 kHz
- ▶ Sampling bit depth: 24-bit
- ▶ Maximum input level: +7 dBu / 5 Vpp
- ▶ Maximum output level: +8 dBu / 5.5 Vpp



electro-harmonix

WWW.EHX.COM



ASIO is a trademark and software of Steinberg Media Technologies GmbH.